

HEALTHCARE



METROPOLITAN QUARRY TILE- THE WORKHORSE of the tile industry. Meets or exceeds all commercial tile standards. One of the most sustainable floor coverings available. Easy to maintain.

Features & Benefits SPOTLIGHT-

Metropolitan Ceramics Unglazed Quarry Tile, time tested for heavy traffic indoors and outdoors- the right choice for many types of healthcare facilities applications. Metropolitan Tile is 1/2" thick and extruded for added durability and slip resistance. Areas such as food prep, walkways and courtyards, entryways, and waiting areas are excellent candidates for a floor finish this rugged, easy to maintain, and naturally attractive.

WILL NOT bubble - chip - melt like other commercial flooring products that can be compromised and fail.

Fired at high temperatures to take the heat of spilled hot oil or other scorching hot substances.

VERY LOW absorption unlike more porous commercial flooring materials. Resists grease- bacteria- dirty water.

NO SEALING is required. Never seal with a surface type sealer. For extreme conditions and areas subject to the spilling of animal fats, oil and grease, we recommend sealing with a simple water-based penetrating sealer.

Heat/Cold Resisting. From the cooler to the fryer stability.

No VOC's. Will not off gas.

Vertical installation Responsive. Expands installation options from floors to walls.

Economically Friendly. Costs less per year than all other floor finishes over the life of a building.

Through The Body Color. Will not wear off and will not show wear patterns or discoloration. Looks as good tomorrow as it does today.

Modular Sizes. Adds pattern and interest to the most basic installations.

Manufactured with Relieved Edges. Relaxed, natural look that resists chipping.

Extruded Not Pressed. Extremely durable for years of heavy use.

Slip Resisting. For areas subject to spills and moisture.

featuring

ENVIRO QUARRY
IN EXCESS OF
50% RECYCLED CONTENT (Pre-consumer)



The right choice for many health care applications

Extremely Long Life Cycle

Low Impact Maintenance

Slip Resistance

Mold/Bacteria Resistance

Indoor/Outdoor Use

METROPOLITAN
CERAMICS
Ironrock Since 1866

P.O. Box 9240 Canton, OH 44711
1-800-325-3945
e-mail: info@ironrock.com
www.metroceramics.com

Trim Pieces

Note: Not all trim pieces are available in all colors. Consult our web site for complete trim details and available options

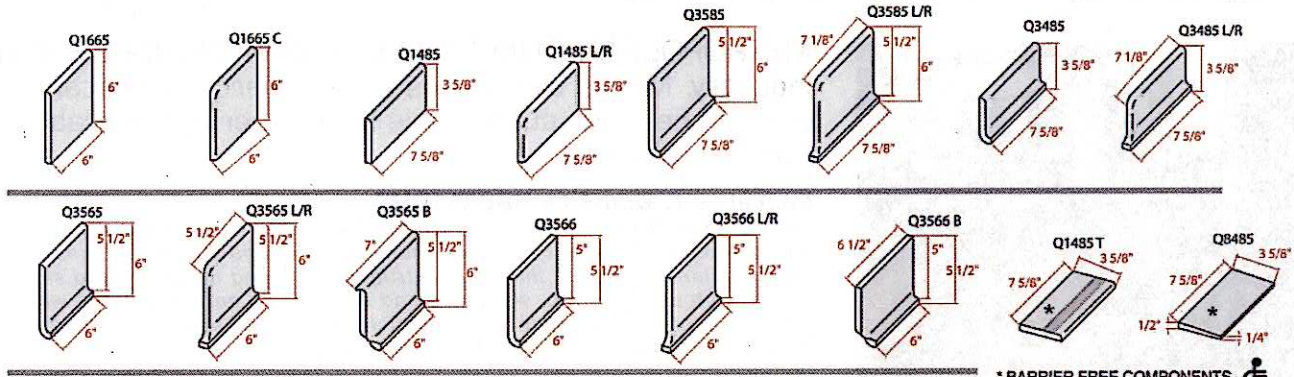

Environmental

Metropolitan Ceramics and LEED. Metropolitan Ceramics products meet requirements for sustainable building and may contribute to a building receiving a level of LEED certification by their use. For more information on Metropolitan Ceramics and the environment, please visit our web site www.metroceramics.com.

Metropolitan Ceramics
is centrally located in Canton, Ohio USA

Metropolitan Ceramics offers two choices for added slip resistance.



QUARRYBASICS® X Colors
Metallic Additive.

Coefficient of Friction
.90 dry and .70 wet at time
of manufacture.

Metropolitan quarry tile is easy to maintain and requires only neutral cleaners and no special power washing!

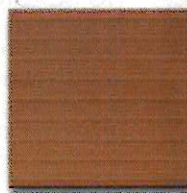

METRO TREAD®
Raised Tread Design- installed
in a checkerboard pattern.

Coefficient of Friction
.90 dry and .70 wet at time
of manufacture.

Metro Tread has the added benefit of ease of cleaning. Will not trap debris. Meets the strictest health department regulations-California- without the need for additional drains.

Test Results- Specifications- Cleaning & Maintenance

Specification	Test	Standard	Result
Abrasion Resistance	ASTM C501	Index of 35 or better	Metropolitan tests at >80 or better.
Absorption 5-hour boil	ASTM C373	5%	Metropolitan tests at 3% maximum and qualifies as vitreous.
Breaking Strength	ASTM C648	Min. 250 lbs.	Metropolitan tests at 400 lbs. or better.
Compressive Strength	ASTM C67	No industry standard	Metropolitan tests at 10,000 P.S.I. or better.
Facial Size Variation	ASTM C499	Average facial dimension of each tile not to exceed 4% from nominal dimension(s)	Metropolitan meets the standard.
Freeze/ Thaw	ASTM C67	No industry standard	ASTM test is 50 cycles.
	Metropolitan internal test	Metropolitan internal standard is 3,000 cycles.	
Shear Bond Strength	ASTM C482	50 P.S.I. or better	Metropolitan exceeds the standard.
Static Coefficient of friction	ASTM C1028	No industry standard	At time of manufacture, All Metropolitan Colors meet or exceed measure of 0.70 dry and 0.60 wet. Metropolitan X-colors and METROTREAD (enhanced slip resisting products) meet or exceed 0.90 dry and 0.70 wet.
Thickness	ASTM C499	Max. range of .050"	Metropolitan meets the standard.
Warpage	ASTM C485	Max. 1.5% along any edge. 1.0% on either diagonal.	Metropolitan meets the standard.
Wedging	ASTM C502	Max. 1.0%	Metropolitan meets the standard.

By ANSI Standard Specification A137.1 Metropolitan Ceramics' unglazed quarry tile is classified as quarry tile, however, the exceptional technical characteristics noted allow them to be used in virtually any application suitable for ceramic tile. Metropolitan Ceramics' unglazed tile meets both the ASTM standards, the ANSI A137.1 specification for quarry tile, and Metropolitan internal standards as listed.

Specifications- Cleaning and Maintenance

For complete specification and cleaning/ maintenance information, including download versions of these documents, please contact our website. www.metroceramics.com

METROPOLITAN
CERAMICS
Ironrock Since 1866

P.O. Box 9240 Canton, OH 44711

1-800-325-3945

e-mail: info@ironrock.com

www.metroceramics.com